

Flexible Solutions QS Series Softwall Cleanrooms

Ship Within 2 Weeks A.R.O.

Easy to Install In One
Day or Less

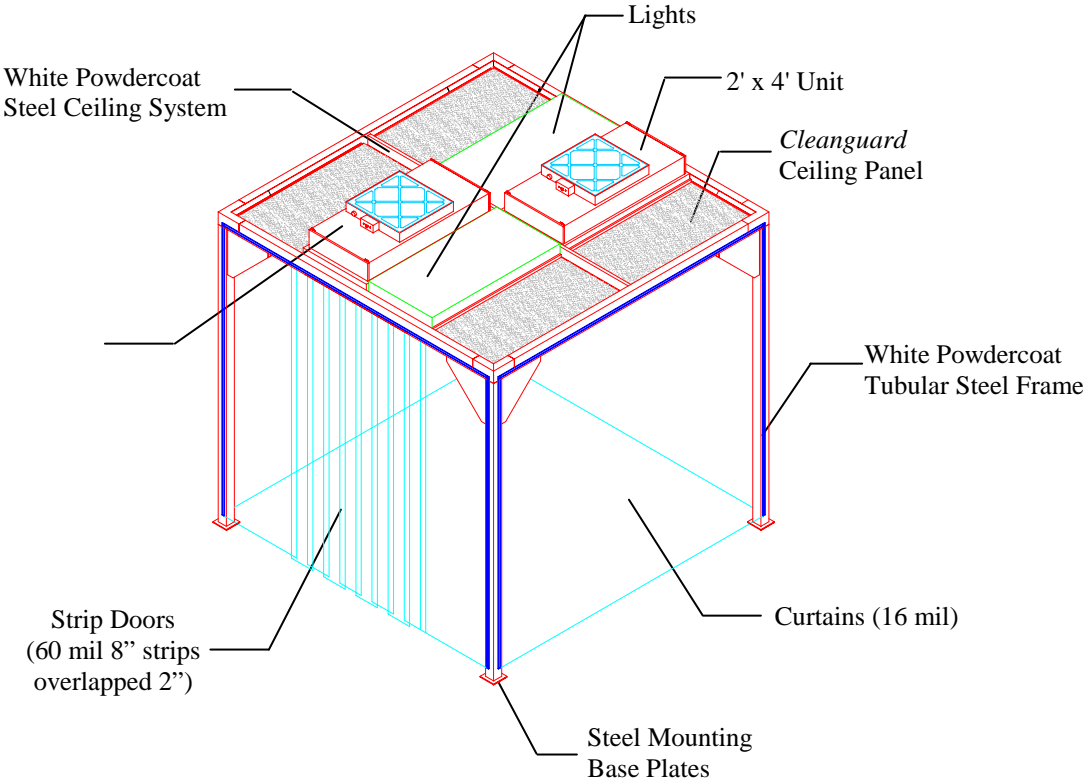
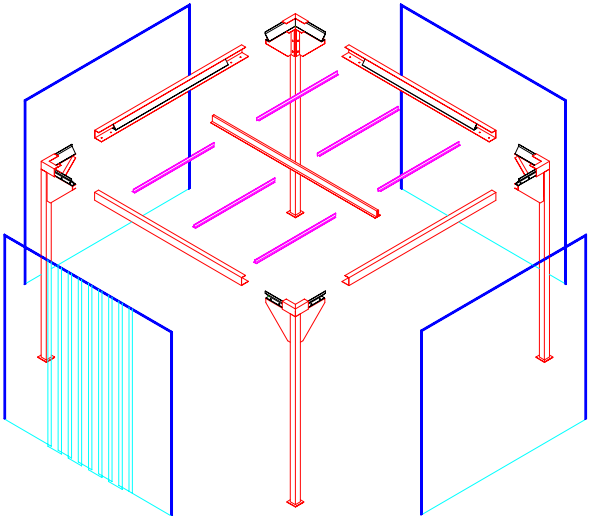

See the next page for a list of standard sizes

QS (Quick Ship) Series

Ship Within 2 Weeks A.R.O.

Using “off the shelf” components, standard 115V SAM 24 Fan Filter Units and standard 120V Cleanroom Light fixtures allows us to ship in two weeks or less.

Model No.	W	Sizes L	ID	Ht	Volts	No. SAM's	No. Lts.	Ceil. Pan	4' Door	Legs
-----------	---	---------	----	----	-------	-----------	----------	-----------	---------	------

(ISO Class 6) Class 1,000

10006	8	X 8	X	8	115V	2	2	4	1	4
10007	8	X 10	X	8	115V	3	2	5	1	4
10008	8	X 12	X	8	115V	4	3	5	1	4
10010	8	X 16	X	8	115V	5	4	7	1	6
10011	10	X 12	X	8	115V	5	3	7	1	4
10012	10	X 16	X	8	115V	6	4	10	1	6
10013	12	X 12	X	8	115V	5	4	9	1	4
10014	12	X 16	X	8	115V	7	5	12	1	6
10015	12	X 20	X	8	115V	9	6	15	1	6
10016	12	X 24	X	8	115V	11	7	18	1	6

(ISO Class 7) Class 10,000

10022	8	X 8	X	8	115V	1	2	5	1	4
10023	8	X 10	X	8	115V	2	2	6	1	4
10024	8	X 12	X	8	115V	2	3	7	1	4
10026	8	X 16	X	8	115V	2	4	10	1	6
10027	10	X 12	X	8	115V	2	3	10	1	4
10028	10	X 16	X	8	115V	3	4	13	1	6
10029	12	X 12	X	8	115V	3	4	11	1	4
10030	12	X 16	X	8	115V	3	5	16	1	6
10031	12	X 20	X	8	115V	4	6	20	1	6
10032	12	X 24	X	8	115V	5	7	24	1	6

(ISO Class 8) Class 100,000

10038	8	X 8	X	8	115V	1	2	5	1	4
10039	8	X 10	X	8	115V	1	2	7	1	4
10040	8	X 12	X	8	115V	1	3	8	1	4
10042	8	X 16	X	8	115V	1	4	11	1	6
10043	10	X 12	X	8	115V	1	3	11	1	4
10044	10	X 16	X	8	115V	1	4	15	1	6
10045	12	X 12	X	8	115V	1	4	13	1	4
10046	12	X 16	X	8	115V	2	5	17	1	6
10047	12	X 20	X	8	115V	2	6	22	1	6
10048	12	X 24	X	8	115V	2	7	27	1	6

No modifications or options are offered for the QS Series.